

Risk Analysis of Highly-integrated Systems

AM II: Part I: Short Introduction to Object-oriented Modeling: Part II: Application to Complex Engineering Systems:

- Stochastic simulation
(basic Monte Carlo methods for reliability analysis)
- Object-oriented modeling approach – framework
- How to build an object-oriented model

Reliability analysis of large-scale electric power systems

- The IEEE Reliability Test System 1996 and its implementation
- Results



PART I: SHORT INTRODUCTION TO OBJECT-ORIENTED MODELING

Stochastic simulation – basic Monte Carlo methods for reliability analysis (I)

Simulation: an abstraction of a real system by a computer program in order to mimic and analyze its behavior

Monte Carlo technique: stochastic simulation using algorithmically generated random numbers

A simple example for estimating the unavailability Q of a system :

Assume a system consisting of N components, where:

s_i : state of the i th component (boolean)

Q_i : failure probability of the i th component

R_i : random number for the i th component; $R_i \sim \text{uniform}[0,1]$

then, assuming independent failures :

$$s_i \begin{cases} 0 & (\text{success}) \text{ if } R_i > Q_i \\ 1 & (\text{failed}) \text{ if } 0 \leq R_i \leq Q_i \end{cases}$$

Stochastic simulation – basic Monte Carlo methods for reliability analysis (II)

1. sample the states of all components („throw the dices“) to get the system state s :

$$s = \{s_1, \dots, s_i, \dots, s_N\}$$

2. Perform system analysis to judge whether s is a failure state or not:

$$x_j = 0 \quad \text{if the system is in the up state}$$

$$x_j = 1 \quad \text{if the system is in the down state}$$

3. Performing k system state samples, the unbiased estimate of the system unavailability then is given by:

$$\bar{Q} = \frac{1}{k} \sum_{j=1}^k x_j$$

with variance:

$$V(\bar{Q}) = \frac{1}{k} V(x) = \frac{1}{k(k-1)} \sum_{j=1}^k (x_j - \bar{Q})^2$$

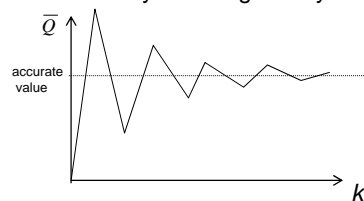

Stochastic simulation – sequential Monte-Carlo simulation

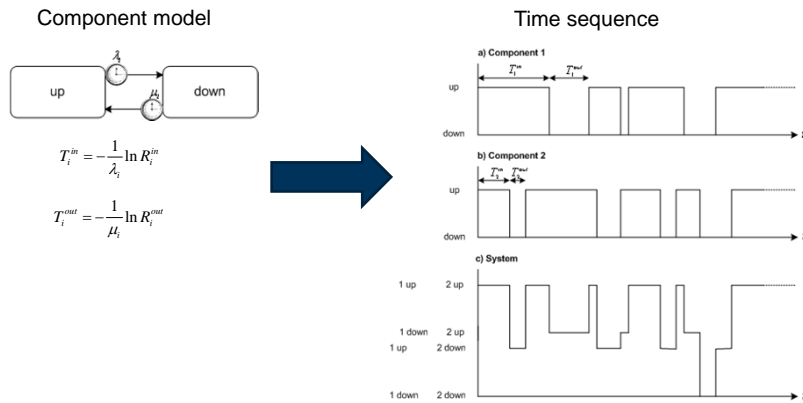

Combining Monte Carlo Techniques with Object-oriented modeling

Advantages for reliability analysis:

- Monte Carlo simulation helps to overcome the problem of the **state space explosion**:
Consider a system of $N=20$ components with two states (e.g. up state and down state). A "state enumeration approach", such as a "complete" fault tree, or a markovian chain would have to consider $2^N=2^{20}=10^6$ system states!
- Object-oriented modeling helps to explicitly consider **time-dependent interactions** between the components and to integrate feedback loops, which is not possible in "static approaches" such as fault tree analysis.

Disadvantages for reliability analysis:

- The simulation primarily aims at calculating mean values. **Some critical scenarios might be missed.**
- Depending on the analyzed system, the **validation** of the simulated system behavior might be a **difficult task**, due to lack of operational experience regarding low-probability-high-impact scenarios.

Object-oriented modeling approach – framework

- Modeling the behaviour of the **components** (objects) and their interaction with the environment
- Stochastic simulation (Monte Carlo methods) of all components to investigate the **macro-behaviour** of the whole system
- In contrary to established methods for risk analysis (ETA, FTA) the observed scenarios and system states *s* are not predefined, but they emerge during the simulation (**emergence**)
- Frequency and consequence of events are determined “**experimentally**”

An object...

- **Has different states (Finite State Machine, FSM)**
- Is capable of interaction with its environment (e.g. other objects)
- has „receptors“ and „effectors“ for specific („messages“) and non-specific (environmental variables) signals
- Can act randomly
- May have a memory (learning)
- Can strive for a goal

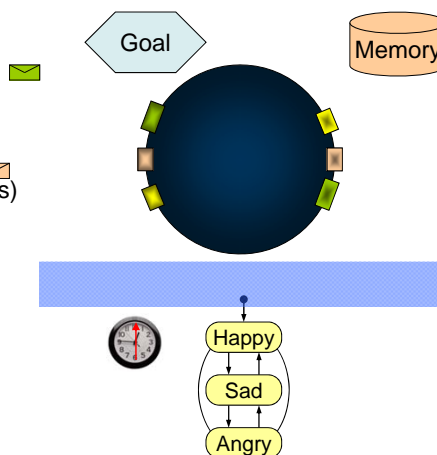

Simulation of N objects

- One single object does not tell us much about the behaviour of its macro-system
- Therefore every component of a system has to be modelled separately by an object
- By the computational simulation of all objects, the global system behaviour and the system states s emerge

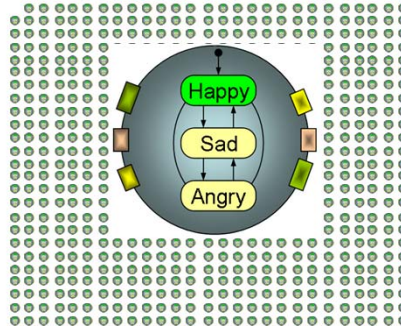

What can be represented by objects?

- Humans (e.g. operators)
- Components (e.g. turbine)
- Machines (e.g. power station)
- Whole systems (e.g. energy)

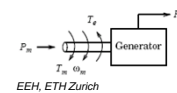

EEH, ETH Zurich

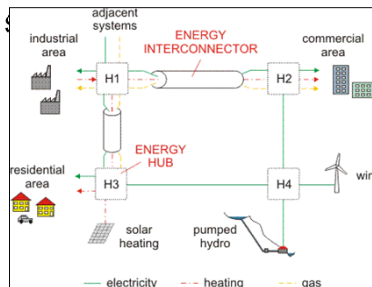

EEH, ETH Zurich

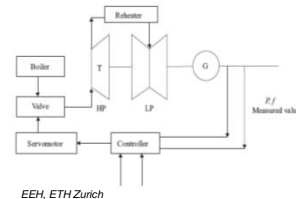

EEH, ETH Zurich

How to build a simplified object-oriented model for reliability analysis

1. Identify the components of the system
2. Determine the states of each component by making use of FSM, eg:



3. Determine the transitions between the states and their triggers (e.g. lapse of time or signal from outside)

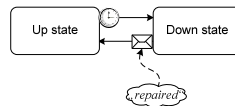

4. Establish the communication among the objects:

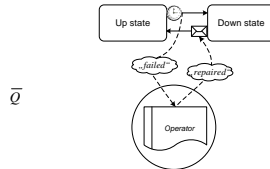

5. Simulate your model to generate the system states s and estimate

PART II: APPLICATION TO COMPLEX ENGINEERING SYSTEMS

Reliability Analysis of Electric Power Systems

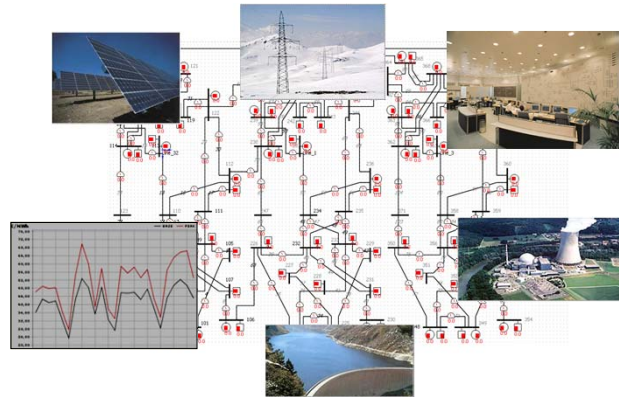

Background and Motivation (I)



Source: UCTE 2006

Developments within the landscape of the European electric power system:

- *electricity market liberalization*
 - intricate, decentralized market structure with numerous competing players
 - extensive (international) trading without adequate technical upgrades
- *increasing amount of distributed generation and renewables*
 - less predictable power sources
 - variable load flow patterns
- *pervasive use of ICT*
 - more intelligent system operation
 - new risks due to interdependencies



Unprecedented operational complexity



Background and Motivation (II)

However:

Reliability policies and assessment methodologies did not keep pace !

➤ *N-1 rule*

- deterministic approach
- predefined set of anticipated faults, focus on „worst-case“ contingencies
- relevant failure states or the actual „worst-case scenario“ might be missed !!

➤ *Current probabilistic approaches*

- limited to specific aspects (e.g. to a single component), or
- oversimplified (e.g. cascading failures)

Modeling the Electric Power System – Two-layers approach:

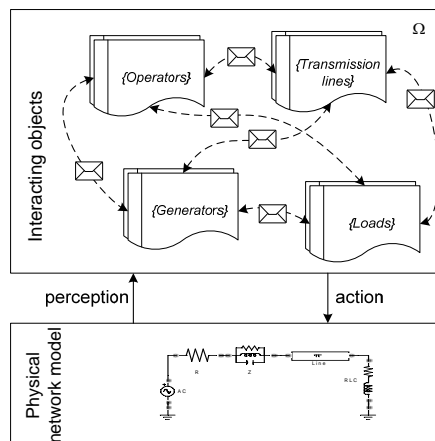

The IEEE Reliability Test System 1996 (RTS '96)

➤ Basic system layout

- 72 busbars
- 107 transmission lines
- 99 generators
- 51 loads
- Voltage levels: 230/138 kV
- Installed capacity: 10'215 MW (CH: ~12'000 MW)
- Peak load: 8'550 MW (CH: 9'650 MW)

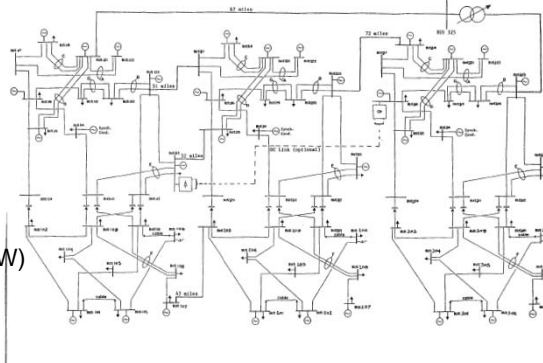

➤ Available data

- physical component data: branch reactances, operational thresholds etc.
- load curves (hourly, daily, weekly)
- reliability data: component outage and repair rates, min. down times, etc.

The RTS '96 - Implementation in AnyLogic

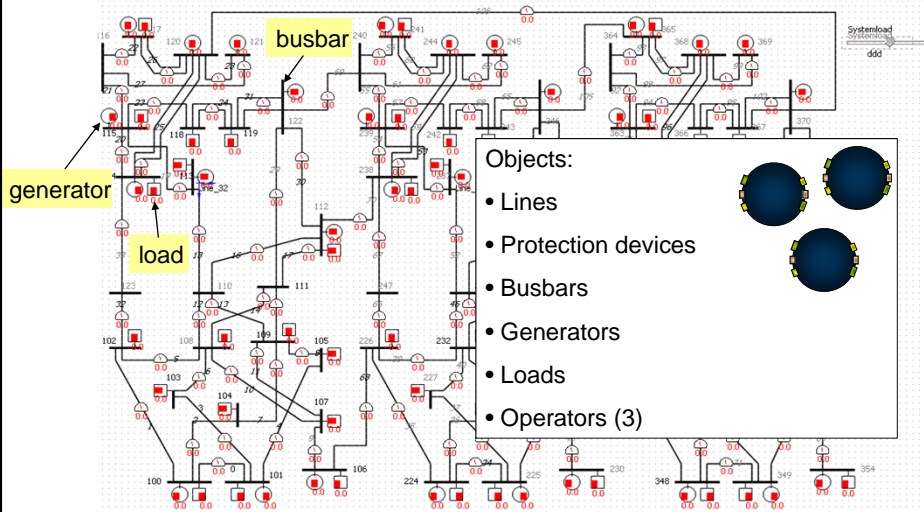

Objects: The Operator as an Example

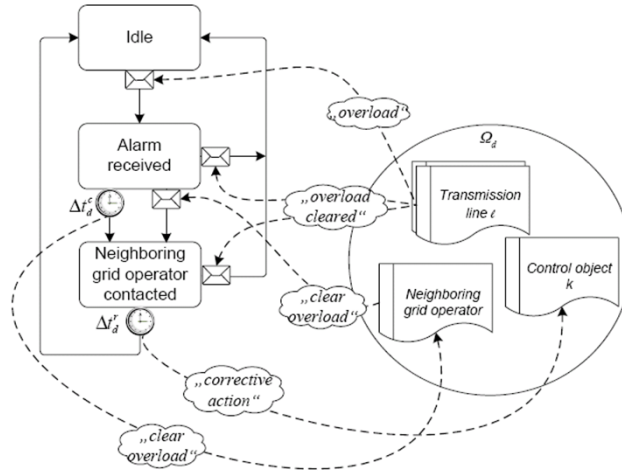

Results: A) Expected Frequencies of Blackouts

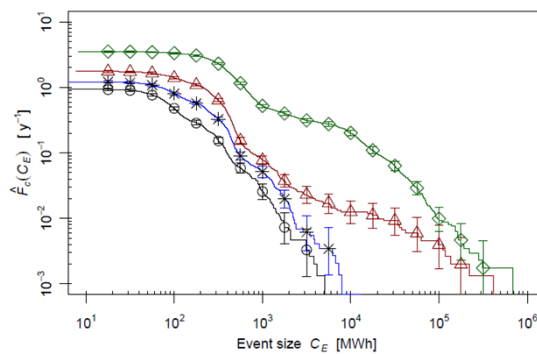

Complementary cumulative blackout frequencies for four different system loading levels $L=1.0, 1.1, 1.2$ and 1.37 (circles, stars, triangles and diamonds, respectively) without operator intervention. The error bars indicate the 90% confidence interval.

Results: B) Blackout causes

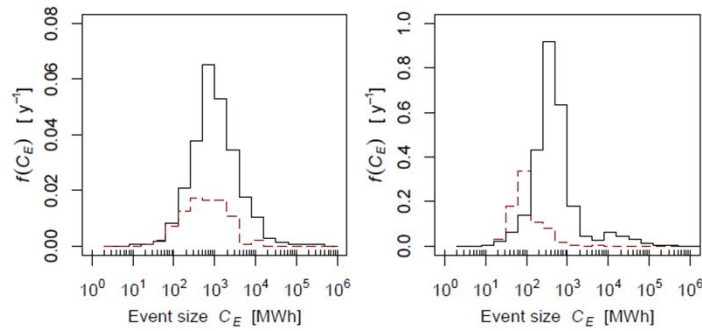

Impact of increasing the system loading from $L=1.0$ (dashed line) to $L=1.37$ (continuous line) on the absolute frequencies of blackouts caused by generation inadequacy (left) and system splitting (right).

Results: C) Influence of the operator response time on the system reliability

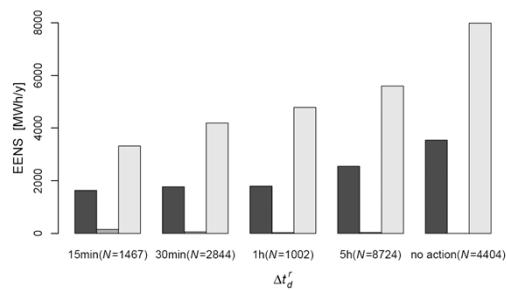

Influence of the operator response time on the EENS due to generation inadequacy (left, black bar), operator action (middle, dark-grey bar) and system splitting (right, light-grey bar) for $L=1.37$.

EENS: Expected Energy Not Supplied